

## Dimensions and other relevant characteristics of the cargo holds of the aircraft that Volaris operates.

For the purposes hereof, Volaris means Concesionaria Vuela Compañía de Aviación, S.A.P.I. de C.V., Vuela Aviación, S.A. and Vuela El Salvador, S.A.

Purpose: Find here the dimensions and clearances of the cargo holds of the aircrafts operated by Volaris, as well as the baggage allowance so that you have information about the capacity and limitations on the transport of your assistive devices. This document is for compliance with U.S. Department of Transportation (DOT) regulations on flights to and from the United States.

### Dimensions and clearances of Volaris cargo compartments

#### A319

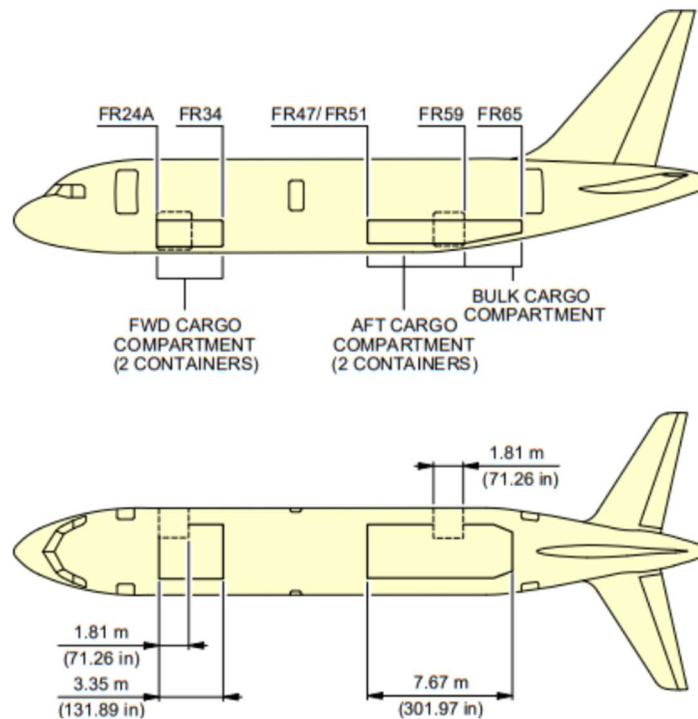

#### FWD Cargo Doors

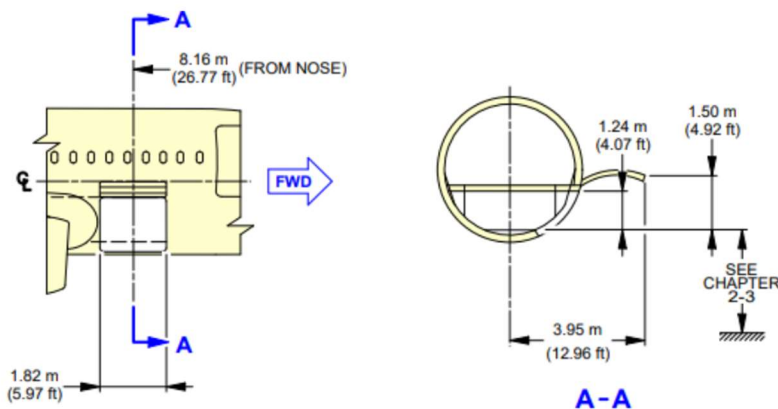

## AFT Cargo Door

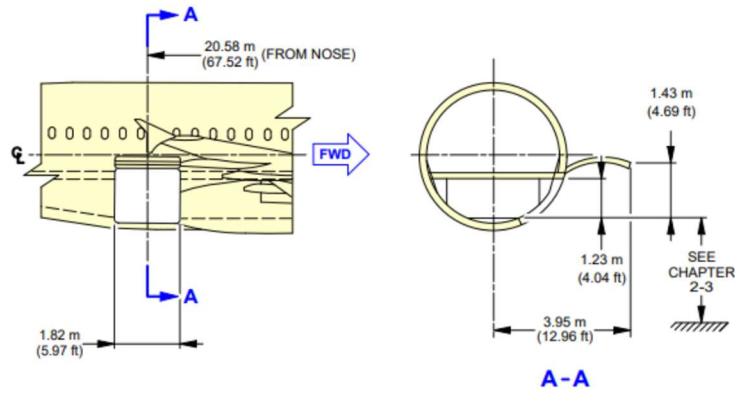

## A320 GENERAL A320CEO/NEO

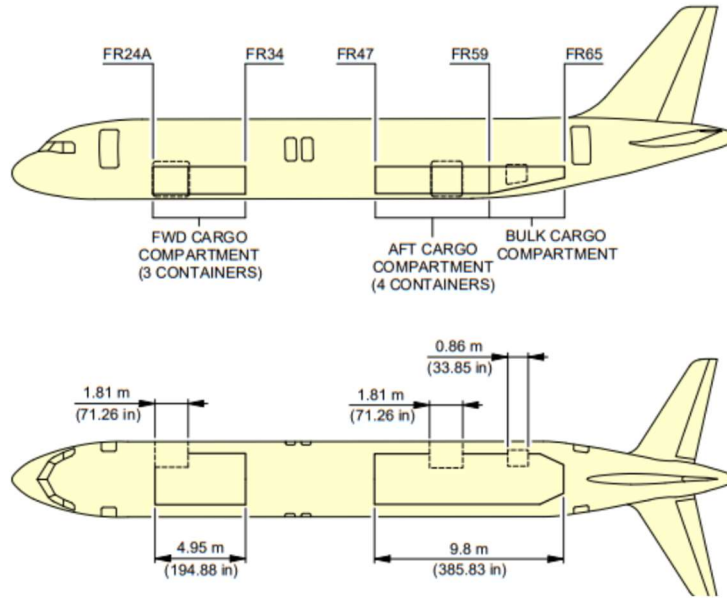

## FWD CARGO DOOR A320CEO

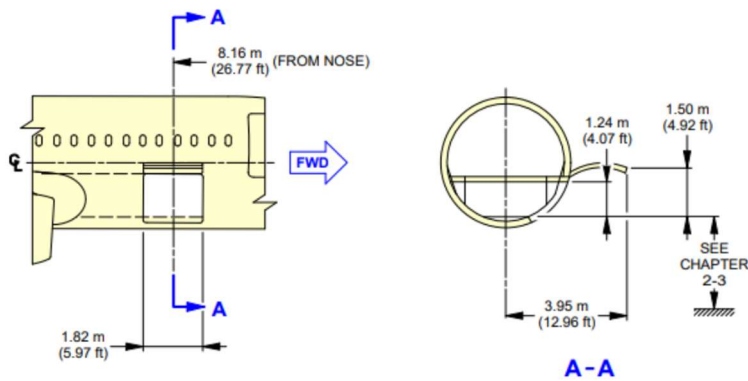

## FWD CARGO DOOR A320NEO

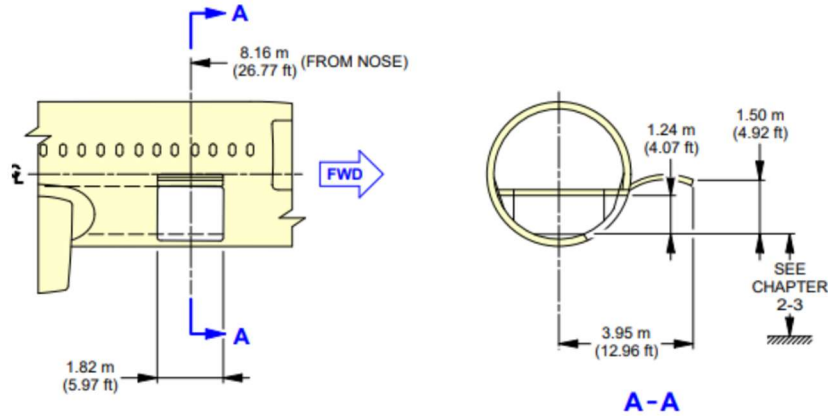

## AFT CARGO DOOR A320CEO/NEO

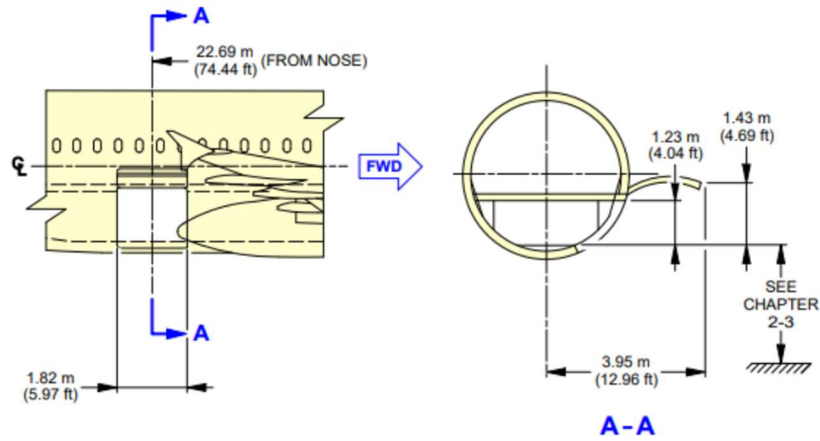

## BULK CARGO DOOR A320CEO/NEO

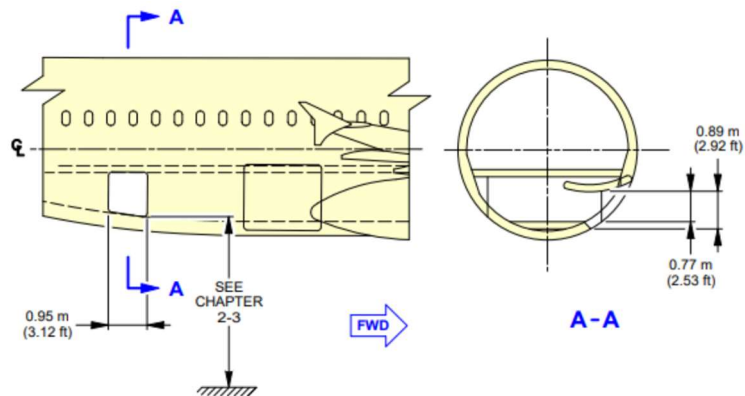

## A321 GENERAL A321CEO/NEO

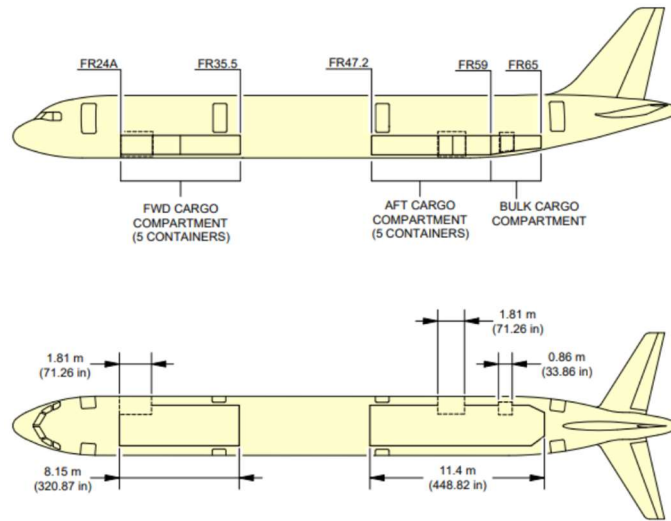

## GENERAL A321NX

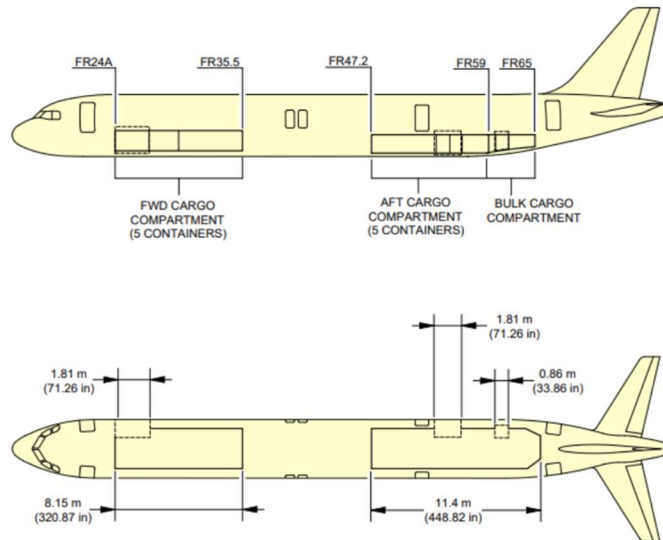

## FWD CARGO DOOR A321CEO

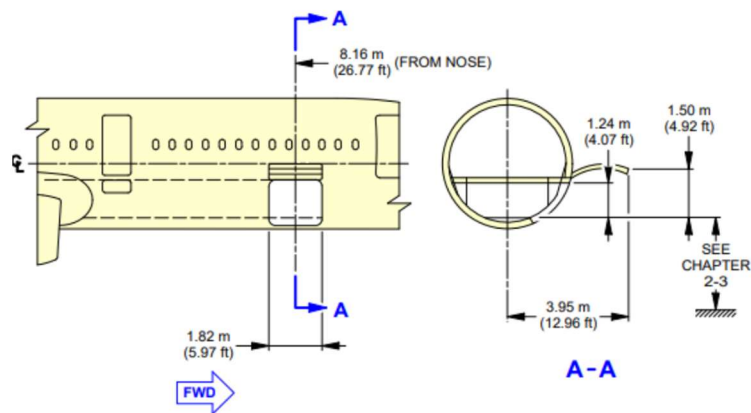

## FWD CARGO DOOR A321 NEO/NX

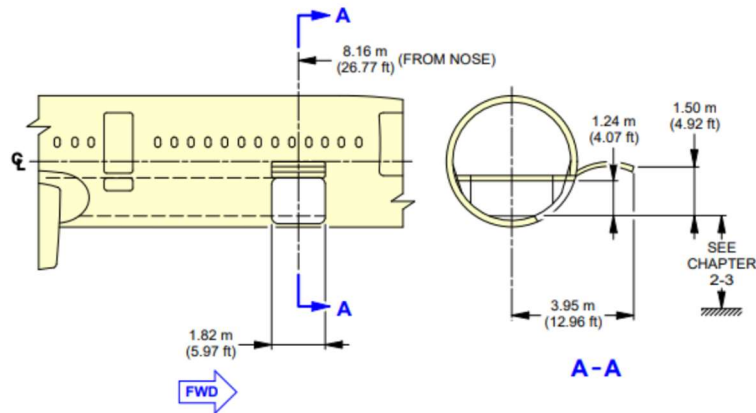

## AFT CARGO DOOR A321CEO/NEO/NX

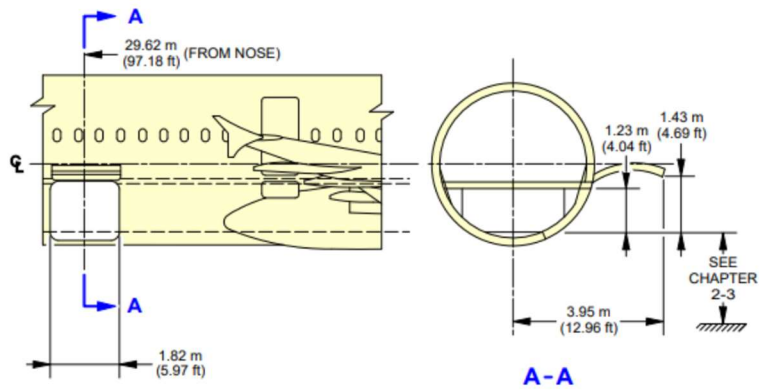

## BULK CARGO DOOR A321CEO/NEO/NX

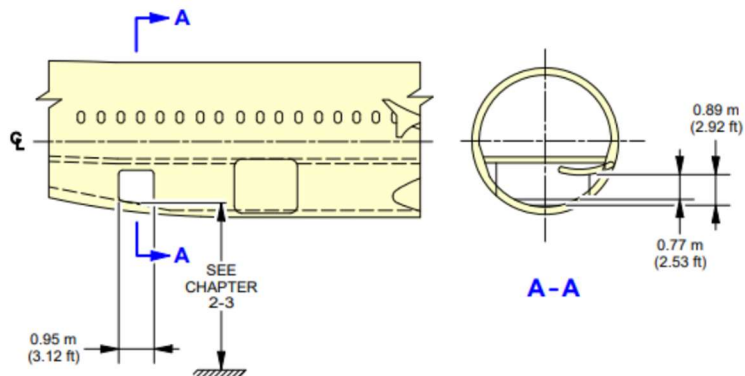

## Passenger baggage allowed in Volaris cargo compartments.

The carriage of the baggage listed below are subject to fees (except for assistive devices) and conditions which are disclosed to the customer on the official Volaris website.

All rights reserved to Volaris, including text and images. Reproduction in whole or in part for purposes other than those stated is prohibited.

- Personal items necessary for the use, comfort, or convenience of the passenger during his/her trip; if it does not exceed the limits established by Volaris.
- The following sporting goods not exceeding a maximum weight of 45 kg:
  - Wind surfing equipment, Golf club case, Golf equipment, Surf boards, Fishing rods, Spear guns and underwater weapons, Sporting firearms, Ammunition (maximum 5Kg per passenger), Sleeping bags, Tennis rackets, Tents, Bicycles, Bowling balls, Football equipment, Non-motorized skateboards or scooters, Inflated or airless sports balls, Skis, Water skis, Scuba diving equipment (empty scuba tank). Baby carriages without batteries.
- Baby car seats.
- Baby walkers.
- Wheelchairs, stretchers, walkers, crutches.
- Musical instruments: Electric and acoustic guitars, electronic and acoustic drums, drums, trumpets, etc.
- Tires.
- Flat tires mounted on a rim.
- Dialysis machines.
- Domestic animals (dogs and cats), except potentially dangerous breeds.
- Domestic animals (dogs and cats), brachycephalic breeds, under the passenger's responsibility.
- Firearms.
- Ammunition (maximum 5Kg per passenger).
- Perishable products contained in appropriate packaging for the product, which avoids leaks or spills of liquids and does not spread bad odors, except on flights to and from the US.
- Flowers and plants, fruits and vegetables, meats, seafood and seafood products, edible items, dairy products, whey.
- Fragile items.
- Oversized baggage
- Mobility aids not exceeding the following maximum dimensions and weight: Length: 1.30 meters, Width: 0.80 meters, Height: 1.00 meters, Weight: 60 kg, powered by the following types of batteries:
  - Non-spillable wet batteries complying with special provision A67.
  - Dry batteries (alkali-manganese, zinc-carbon, and nickel-cadmium) complying with special provision A123.
  - Nickel-metal hydride batteries complying with special provision A199.
  - Lithium batteries complying with UN 38.3 tests. [Check the complete requirements here](#)

Baggage will be transported in accordance with the provisions of the General Operations Manual (MGO) and its complementary manuals, such as: Ground Operations Manual (MOT), Cargo Operations Manual (MOC) and the Security Program for the Prevention of Acts of Unlawful Interference (PSPAII), which are approved by the Federal Civil Aviation Agency (AFAC) of Mexico, as well as the applicable laws of the countries of origin and destination operated by Volaris.